

Product

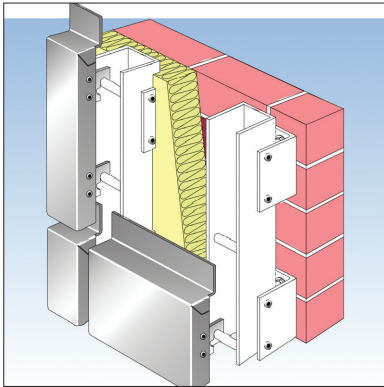

- THIS DETAIL SHEET RELATES TO FF2 AND FF2plus PVDF COIL-COATED ALUMINIUM COIL AND SHEET, FOR USE AS EXTERNAL CLADDING.
- The product is available in a range of colours and two gloss levels (20 units and 40 units).
- FF2plus is the same product as FF2, with the application of a sound-deadening film to the reverse side.

This Detail Sheet must be read in conjunction with the Front Sheets, which give the product's position regarding the Building Regulations, general information relating to the system, and the Conditions of Certification.

Technical Specification

1 Description

1.1 FF2 and FF2plus PVDF Coil-Coated Aluminium Coil and Sheet is manufactured from 2 mm thick aluminium alloy of grade AW 5754 to BS EN 573-3 : 1995, temper designation H42 to BS EN 515 : 1993.

1.2 The product is coil-coated with a primer and PVDF topcoat to a total thickness of 25 µm (or from 35 µm to 40 µm for metallic colours). A lacquer coat 3 µm thick is applied to the reverse side.

1.3 The product is available in a range of metallic and non-metallic colours at gloss levels of 40 and 20 respectively.

1.4 A protective polyethylene film, printed with the Novelis and FF2 logos, is applied to the top surface of the product.

1.5 The FF2plus product is made by the application of 0.14 mm thick aluminium foil to the reverse side of the FF2 product using a sound-dampening adhesive. No assessment has been made by the BBA of the effectiveness of the sound dampening properties of the FF2plus product.

2 Delivery and site handling

FF2 and FF2plus are supplied in sheet form (FF2 can also be supplied in coil form) to specialist companies who form façade elements using a variety of folding, bending and roller curving machines. These façade elements are then delivered directly to site.

Design Data

3 General

3.1 FF2 and FF2plus PVDF Coil-Coated Aluminium Coil and Sheet, after fabrication into façade elements, is suitable for use as non-loadbearing cladding.

3.2 Some coloured coatings are directional. To avoid contrasts all sheets should be fixed in the same (machine) direction, using the information printed on the protective film as a guide. Each elevation should be clad with material from the same batch.

4 Workability

4.1 The product may be worked by conventional techniques including brake-pressing, roll forming, bending, drilling and punching. It is essential that the correct tools, in good condition, are used, to prevent any damage to the coating, and that any swarf should be removed.

4.2 To avoid cracking during forming, bends should be preformed at a minimum temperature of 20°C and at a minimum bending radius of 5 mm (equivalent to 2.5T, according to BS EN 13523-7 : 2001).

5 Performance in relation to fire

5.1 When tested to BS 476-6 : 1989, a sample of the product with colour reference 1775 achieved an index performance I=0 with sub-index (i₁=0) and to BS 476-7 : 1997, achieved a Class 1 surface. This product,

therefore, has a Class 0 or 'low risk' surface as defined in the national Building Regulations.

5.2 A sample of colour reference 17H8 of the product, when tested to BS 476-3 : 1958 had an EXT.S.AA rating.

5.3 This performance may not be achieved by other colours of the product. The designations of other colours should be confirmed by:

England and Wales

Test or assessment in accordance with Approved Document B, Appendix A, clause 1

Scotland

Test to conform with Table to Annex 2C⁽¹⁾ or 2E⁽²⁾ of Regulation 9

(1) Technical Handbook (Domestic).

(2) Technical Handbook (Non-Domestic).

Northern Ireland

Test or assessment by a UKAS accredited laboratory or an independent consultant with appropriate experience.

5.4 The reverse sides of FF2 and FF2plus (ie incorporating the sound deadening film) are also Class 0 or 'low risk' surfaces.

6 Durability



6.1 The product will perform effectively as a cladding, with an ultimate life of at least 30 years.

6.2 In some industrial environments, maintenance painting to restore the sheet's appearance may be necessary after 20 years.

6.3 A planned maintenance cycle should be introduced if an extended design life is required.

Installation

7 General

The installation of FF2 and FF2plus PVDF Coil-Coated Aluminium Coil and Sheet façade elements is carried out in accordance with BS 8200 : 1985 and the Certificate holder's installation instructions.

Bibliography

BS 476-3 : 1958 *Fire tests on building materials and structures — External fire exposure roof test*

BS 476-6 : 1989 *Fire tests on building materials and structures — Method of test for fire propagation for products*

BS 476-7 : 1997 *Fire tests on building materials and structures — Method of test to determine the classification of the surface spread of flame of products*

BS 8200 : 1985 *Code of practice for design of non-loadbearing external vertical enclosures of buildings*

BS EN 515 : 1993 *Aluminium and aluminium alloys — Wrought products — Temper designations*

BS EN 573-3 : 1995 *Aluminium and aluminium alloys — Chemical composition and form of wrought products — Chemical composition*

BS EN 13523-7 : 2001 *Coil coated metals — Test methods — Resistance to cracking or bending (T-bend test)*



On behalf of the British Board of Agrément

Date of Second issue: 20th September 2005

Chief Executive

*Original Detail Sheet issued 9th March 2004. This amended version includes a change of name of Certificate holder and product name.

British Board of Agrément

P O Box No 195, Bucknalls Lane
Garston, Watford, Herts WD25 9BA
Fax: 01923 665301

©2005

e-mail: mail@bba.star.co.uk
website: www.bbacerts.co.uk



For technical or additional information, contact the Certificate holder (see front page).
For information about the Agrément Certificate, including validity and scope, tel: Hotline 01923 665400, or check the BBA website.