

# STOCKAL<sup>®</sup>

Prepainted  
aluminium  
rolled  
products  
for building  
and industrial  
applications

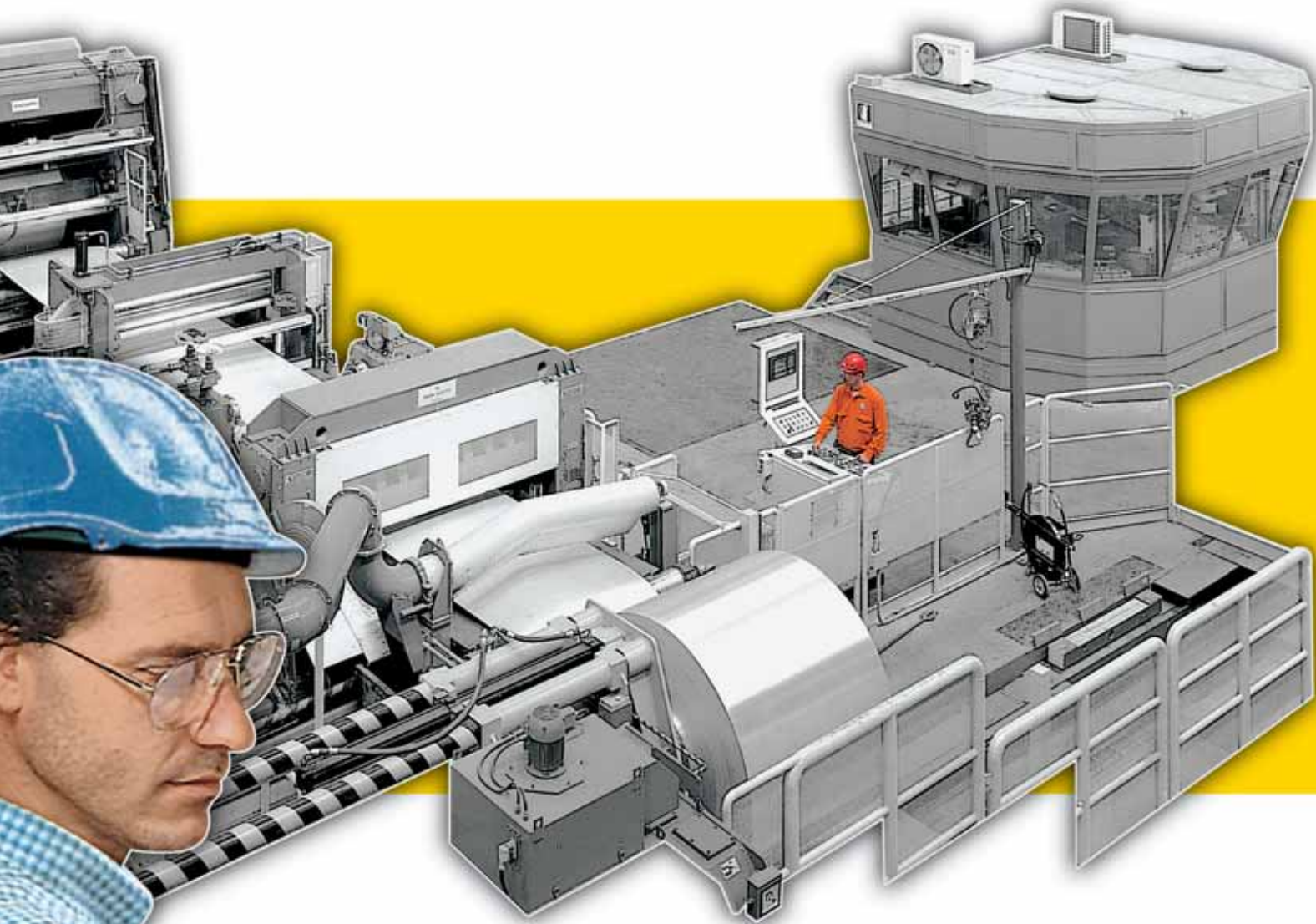



Novelis is the world leader in aluminum rolling, producing an estimated 19 percent of the world's flat-rolled aluminum products. They are the N°. 1 rolled products producer in Europe, South America and Asia, and the N°. 2 producer in North America. Novelis is globally positioned, operating in 11 countries with approximately 12,900 employees. Formed as a Canadian corporation in January 2005, Novelis is a wholly owned subsidiary of Hindalco Industries Limited - Asia's largest integrated producer of aluminium and a leading producer of copper. Based in Mumbai, India, Hindalco is one of the most cost-efficient aluminium producers globally.

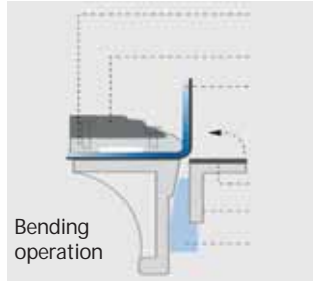
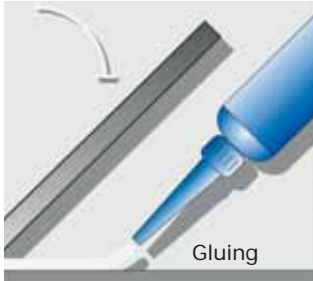
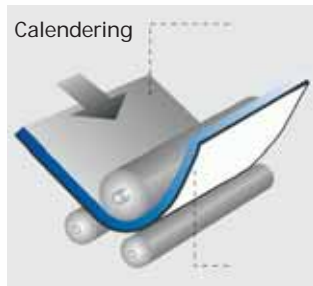
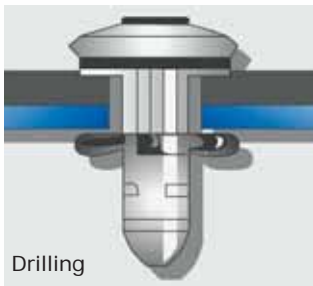

STOCKAL® is characterised by an extraordinary degree of workability. Thanks to its chemical and mechanical characteristics, due to the combination of a EN AW 5010 alloy and polyester based liquid paints, STOCKAL® can be easily worked using the main mechanical working processes: bending, drilling, milling and cutting; these are only part of the standard working processes for STOCKAL®. The use of a special protective liquid coating on the reverse side makes STOCKAL® also suitable for gluing and bonding.

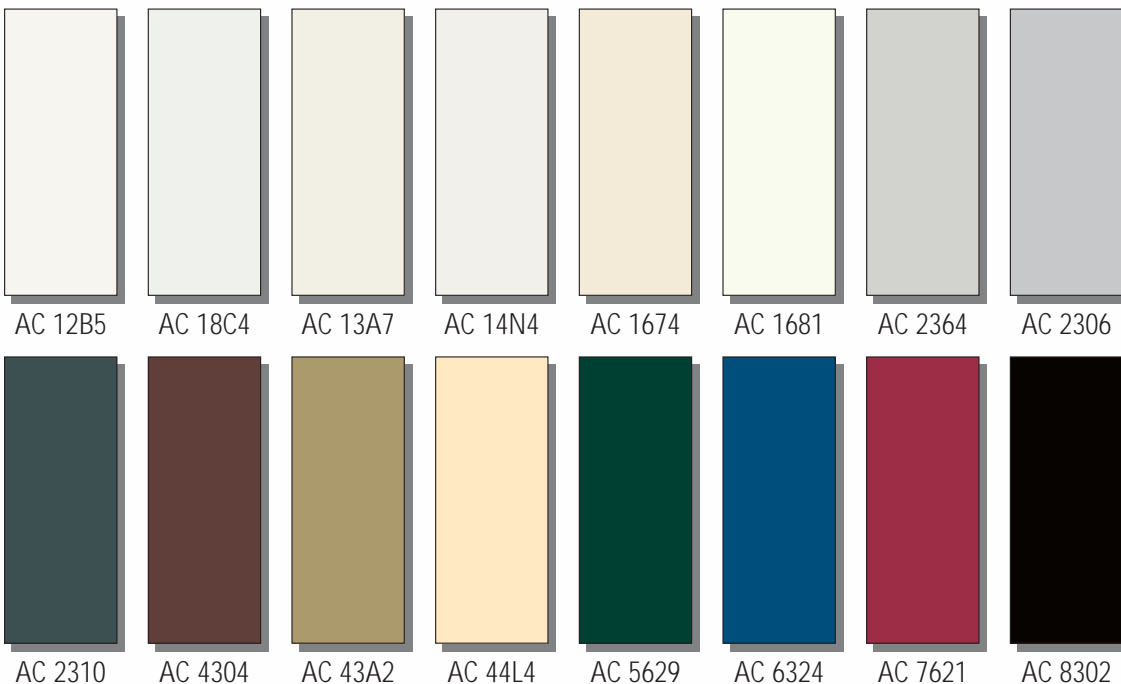

This colour chart includes proposals of pre-painted aluminium colours available in matt, demi and high gloss versions. It is possible to realise pre-painted aluminium coils on sample bases. The colours are as close as printing technique allows. We suggest to ask for an original painted aluminium sample.

Technical Sheet - STOCKAL®			
<b>Product description</b> Aluminium alloy: Metal gauge: Temper: Coating top side: Backing coat:	- [mm] - - -	UNI-EN AW-5010 1.00 - 2.00 H42 Polyester paint Protective lacquer	<b>Norms</b> UNI-EN 573/3  int. standards int. standards int. standards
<b>Metal specification</b> Mechanical properties after coating - transverse to rolling direction Rm: Rp0.2: A50:  Tolerance on dimensions:	[MPa] [MPa] [%]  	110 - 150 90 min 5 min from 1.00 mm up to 1.50 mm 6 min over 1.50 mm up to 2.00 mm Gauge Width and Length	<b>Norms</b> int. standards   UNI-EN 485/4 UNI-EN 485/4

### CERTIFICATES

**Health and Safety Management System:**  
BSI OHSAS 18001; 1999

**Environment Management System Certificate:**  
EN ISO 14001; 2004

**Quality Management System Certificate:**  
EN ISO 9001; 2000

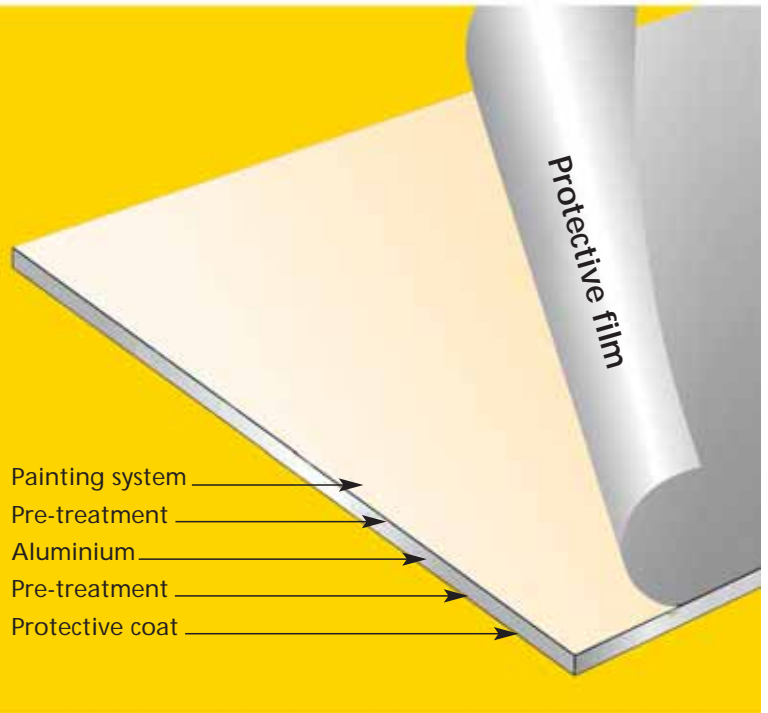

Technical Sheet - STOCKAL®			
<b>Pre-treatment</b> Degreasing and chromium free treatment on top and reverse side			
<b>Organic coating specification</b> (ECCA and UNI-EN 1396)			
Coating system:			<b>Top side</b> Polyester
Typical coating thickness:	ECCA T1	[µm]	22
Pencil hardness:	ECCA T4	KOH-I-NOR	H
Specular gloss to 60°:	ECCA T2	[units]	10 - full gloss
Adhesion 90°/180°:		[%]	100
Adhesion on cross hatch + impact:		[%]	100
M.E.K. / Solvent rubbing test:	ECCA T11	double rubs	150
Resistance to craking on bending:	ECCA T7	-	1.0 T from 1.00 mm up to 1.20 mm 1.5 T over 1.20 mm up to 1.50 mm 2.0 T over 1.50 mm up to 2.00 mm
			<b>Backing coat</b> Polyester 4 approx. not relevant 30 - full gloss not relevant 100 > 50

Novelis Group is an important entity in Italy, too. There are two plants near Milan - Bresso and Pieve Emanuele. Novelis' Bresso plant produces prepainted rolled products using a range of paints and surface finishes. Pieve plant produces aluminium coil and sheet. It is equipped with casters and cold rolling facilities.

Novelis is present throughout the whole Italian market thanks to its four sales centres in Verona, Bologna, Florence and Rome.

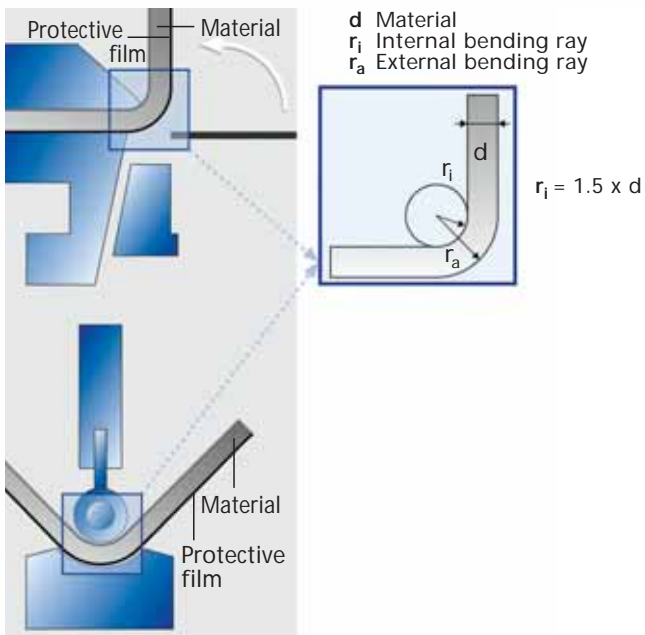

STOCKAL® is the Novelis brand name for its aluminium sheet prepainted with polyester based liquid paints. STOCKAL® is eminently suitable for use in the building industry, especially for façade cladding and window flashings. The wide range of colours and the extraordinary workability of the aluminium substrate make STOCKAL® the most versatile material produced by Novelis.



Copyright © 2003 - Printed in Italy - E-1661/2003

## Novelis Italia

Via V. Veneto, 106  
20091 Bresso (MI)

Tel.: ++39 02 61454.1  
Fax: ++39 02 61454.208  
e-mail: [info.bresso@novelis.com](mailto:info.bresso@novelis.com)  
web: [www.novelispaainted.com](http://www.novelispaainted.com)

The picture utilized in the brochure are from Novelis archive. Novelis maintains the right to update and modify the contents of this product description at any time.